

JVC

SERVICE MANUAL

COMPACT VHS CAMCORDER

GR-AXM226U, AXM231U, SXM530U, SXM535U, SXM536U

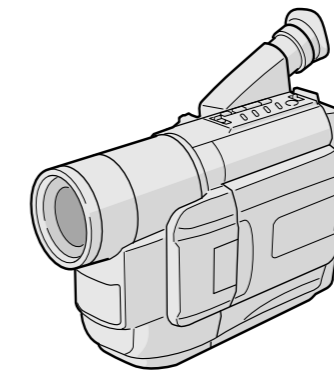

DIC
DIGITAL
STILL CAMERA

S-VHS VHS
PAL
625

Super VHS
Super VHS ET

JVC SERVICE & ENGINEERING COMPANY OF AMERICA DIVISION OF JVC AMERICAS CORP.

Head office	: 1700 Valley Road Wayne, New Jersey 07470-9976	(973)315-5000
East Coast	: 10 New Maple Avenue Pine Brook, New Jersey 07058-9641	(973)396-1000
Midwest	: 705 Enterprise Street Aurora, Illinois 60504-8149	(630)851-7855
West Coast	: 5665 Corporate Avenue Cypress, California 90630-0024	(714)229-8011
Atlanta	: 1500 Lakes Parkway Lawrenceville, Georgia 30043-5857	(770)339-2582
Hawaii	: 2969 Mapunapuna Place Honolulu, Hawaii 96819-2040	(808)833-5828

JVC CANADA INC.

Head office	: 21 Finchdene Square Scarborough, Ontario M1X 1A7	(416)293-1311
Montreal	: 16800 Rte Trans-Canadienne, Kirkland, Quebec H9H 5G7	(514)871-1311
Vancouver	: 13040 Worster Court Richmond, B.C. V6V 2B3	(604)270-1311

JVC

S40895-03

Printed in Japan

Regarding service information other than these sections, refer to the GR-AXM230U, SXM330U service manual (No. 86595). Also, be sure to note important safety precautions provided in the service manual.

SPECIFICATIONS *(The specifications shown pertain specifically to the model GR-SXM530U)*

Camcorder		Operating temperature	Digital S-Video
General		: 0°C to 40°C (32°F to 104°F)	: ø2.5 mm, 4-pole, mini-head jack
Format	: S-VHS/VHS NTSC standard	Operating humidity : 35% to 80%	Y : 1 V (p-p), 75 Ω, analog output
Power source	: DC 11 V (Using AC Adapter) DC 6 V (Using battery pack)	Storage temperature : -20°C to 50°C (-4°F to 122°F)	C : 0.29 V (p-p), 75 Ω, analog output
Power consumption		Weight : Approx. 920 g (2.1 lbs)	
Viewfinder on	: 4.7 W	Dimensions : 206 mm x 112 mm x 118 mm (8-1/8" x 4-7/16" x 4-11/16") (with the LCD monitor closed and with the viewfinder fully tilted downward)	AC Adapter AP-V10U
LCD monitor on	: 5.4 W		Power requirement
Video light	: 3.0 W		U.S.A. and Canada : AC 120 V~, 60 Hz
Signal system	: NTSC-type		Other countries : AC 110 V to 240 V~, 50 Hz/60 Hz
Video recording system		Pickup : 1/4" format CCD	Output : DC 11 V , 1 A
Luminance	: FM recording	Lens : F1.6, f = 3.9 mm to 62.4 mm, 16:1 power zoom lens with auto iris and macro control, filter diameter 40.5 mm	Dimensions (W x H x D) : 59 mm x 31 mm x 69 mm (2-3/8" x 1-1/4" x 2-3/4")
Color	: Converted sub-carrier direct recording Conforms to VHS standard	Viewfinder : Electronic viewfinder with 0.5" black/white CRT	Weight : Approx. 130 g (0.29 lbs)
Cassette	: / cassette	White balance adjustment : Auto/Manual adjustment	Optional Accessories
Tape speed		LCD monitor : 2.5" diagonally measured, LCD panel/TFT active matrix system	• Battery Packs BN-V12U, BN-V20U, BN-V400U
SP	: 33.35 mm/sec. (1-5/16 ips)	Speaker : Monaural	• A/V (Audio/Video) Cable
EP	: 11.12 mm/sec. (7/16 ips)	Connectors	• S-Video Cable QAM0004-004
Recording time (max.)		Video : 1 V (p-p), 75 Ω unbalanced, analog output (via Video output connector)	• Compact S-VHS () Cassettes ST-C-40/30/20
SP	: 40 minutes	Audio : 300 mV (rms), 1 kΩ analog output (via Audio output connector)	• Compact VHS () Cassettes TC-40/30/20
EP	: 120 minutes (with TC-40)		• Active Carrying Bag CB-V7U
D.S.C. format			
Recording format	: Digital data storage (based on JPEG)		
Recording medium	: Built-in flash memory, 2 Mbyte		
Number of storable shots			
FINE mode	: approx. 30 shots		
STANDARD mode	: approx. 60 shots		
Image size	: 640 x 480 pixels (when captured on a PC)		

Specifications shown are for SP mode unless otherwise indicated. E & O.E. Design and specifications subject to change without notice.

This service manual is printed on 100% recycled paper.
COPYRIGHT © 2000 VICTOR COMPANY OF JAPAN, LTD.

No. 86608
December 2000

TABLE OF CONTENTS

DIFFERENT TABLE		1 to 3
5. PARTS LIST		
5.1 PACKING AND ACCESSORY ASSEMBLY <M1>		5-1
5.2 ELECTRICAL PARTS LIST		
MAIN BOARD ASSEMBLY <01>		5-3

The following table indicate main different points between models GR-SXM330U, SXM535U/UC, SXM530U, SXM536UC, AXM230U, AXM231U and GR-AXM226UC.

ITEM \ MODEL	GR-SXM330U	GR-SXM535U/UC	GR-SXM530U	GR-SXM536UC	GR-AXM230U	GR-AXM231U	GR-AXM226UC
BATTERY PACK	BN-V11U	←	←	←	←	BN-V20BU	BN-V11U
BODY COLOR	Metallic gray	Silver	Metallic gray	Silver	Mold Black	←	←
DC LIGHT	Used	←	←	←	←	Not used	←
DSC	Not used	←	Used	←	Not used	←	←
LCD MONITOR	2.5"	3"	2.5"	2.5"	2.5"	2.5"	2.5"
NIGHT ALIVE	Used	←	Not used	Used	Not used	←	←
PC CONNECTION CABLE	Optional	←	←	Provided	Optional	←	←
S-VHS ON/OFF	Used	←	←	←	Not used	←	←

The following table indicate different parts number between models GR-SXM330U, SXM535U/UC, SXM530U, SXM536UC, AXM230U, AXM231U and GR-AXM226UC.

PACKING AND ACCESSORY ASSEMBLY <M1> Note: As for IB (INSTRUCTIONS), refer to sec.5.

REF. NO.	ITEM \ MODEL	GR-SXM330U	GR-SXM535U	GR-SXM535UC	GR-SXM530U	GR-SXM536UC	GR-AXM230U	GR-AXM231U	GR-AXM226UC
		1	PACKING CASE	LY32179-004A	←	←	←	LY32179-005A	LY32179-002A
7	REGIST.CARD/WARRANTY CARD	BT-51020-2	←	BT-52004-1	BT-51020-2	BT-52004-1	BT-51020-2	←	BT-52004-1
△ 11	BATTERY PACK	YQ10629A	←	←	←	←	←	LY31199-001A	YQ10629A
14	CORE FILTER	-	-	-	-	QQR0491-002,X2	-	-	-
15	PC CONNECTION CABLE	-	-	-	-	QAM0084-001	-	-	-
16	REMOTE CONTROL UNIT	LY42129-001A	-	←	←	←	-	-	-
18	AAA(R03)BATTERY	Used	Not used	←	←	←	Not used	Not used	Not used
19	CD ROM	-	-	-	-	LY31133-001B	-	-	-
20	POLY BAG	-	-	-	-	LY30023-010A	-	-	-
21	SER.NET CARD	-	-	BT-20071B	-	BT-20071B	-	-	BT-20071B
22	SOFT WARE PERM.	-	-	-	-	YU30843-4	-	-	-
△ 25	IB(SOFT)(EN)	-	-	-	-	LYT0309-001B	-	-	-
26	SHEET(INSTALL)	-	-	-	-	LYT0309-004A	-	-	-
27	SHEET(AGREEMENT)	-	-	-	-	LYT0378-003A	-	-	-
31	SPACER(PACKING)	-	LY43032-001A	←	-	-	-	-	-

Note: Mark - is not used. Mark ← is same as left.

FINAL ASSEMBLY <M2>

REF. NO.	MODEL ITEM	GR-SXM330U	GR-SXM535U/UC	GR-SXM536UC	GR-SXM530U	GR-AXM230U	GR-AXM231U	GR-AXM226UC
101	LOWER CASE ASSY	LY20684-008A	←	LY20684-009A	←	LY20684-005A	←	←
104	FRONT COVER ASSY	LY20683-005B	LY20683-015A	←	LY20683-017A	LY20683-008B	LY20683-002B	←
104E	DC LIGHT/COVER(LIGHT)	LY32040-001A	←	←	←	←	LY30934-015A	←
104F	SPACER(A)	LY30029-0B4A	←	←	←	←	-	-
104H	CAUTION LABEL	YQ44341-6	←	←	←	←	-	-
104J	STICKER(A)	LY32058-002A	←	←	←	←	LY32058-001A	←
104K	STICKER(C)	LY32060-003A	←	←	LY32060-001A	←	←	←
105	CASS.COVER(M)ASSY	LY20694-004A	LY20694-002A	←	LY20694-004A	LY20694-001A	←	←
106	UPPER CASE(M)	LY10257-015A	LY10257-013A	LY10257-028A	LY10257-017A	LY10257-019A	LY10257-026A	LY10257-027A
109	TOP OPE UNIT	LY20614-012B	LY20614-009B	LY20614-008B	LY20614-007B	LY20614-010B	LY20614-004B	←
114	STICKER(D)	LY32061-005A	←	LY32061-004A	←	LY32061-005A	←	←
130	FRAME ASSY	LY20678-001A	←	←	←	←	LY20678-002A	←
130E	CONTACT(LIGHT),X2	YQ43810-1-1	←	←	←	←	-	-
130F	E-SI C WIRE C-F	WJM0167-001A	←	←	←	←	-	-
136	SCREW/SPECIAL SCREW	*QYSLSF2060D	LY42981-001A	←	←	*QYSLSF2060D	LY42981-001A	←
154	HOLDER(DSC P.)	-	-	LY20645-001A	←	-	-	-
155	SCREW	-	-	QYSLSF2060D	←	-	-	-
156	FPC(DSC)ASSY	-	-	LY42875-001A	←	-	-	-
156A	S.SHEET(DSC FPC)	-	-	LY42876-001A	←	-	-	-
157	INSULATER	-	-	YU40341	←	-	-	-

OPTICAL BLOCK SECTION

REF. NO.	MODEL ITEM	GR-SXM330U	GR-SXM535U/UC/536UC	GR-SXM530U	GR-AXM230U	GR-AXM231U/226UC
257	CCD BASE ASSY	LYH40018-006A	←	LYH40047-001A	←	←

MECHANISM ASSEMBLY <M3>

REF. NO.	MODEL ITEM	GR-SXM330U	GR-SXM535U/UC/536U/530UC	GR-AXM230U	GR-AXM231U/226UC
400	MECHA(B)ASSY	YMA0031A-E	←	YMA0030A-E	←
406	CASS.GUIDE(R)ASSY	YQ44339A-7	←	-	-
406A	SW.LEVER(R)	YQ32162-1-3	←	-	-
406B	TORSION SPRING	YQ44340-1-4	←	-	-
407	SCREW	LY42819-001A	←	-	-
466	ROTARY ENCODER	QSW0888-002	←	QSW0888-001	←

Note: Mark - is not used. Mark ← is same as left. Mark * reference model was also changed.

MONITOR ASSEMBLY <M5>

REF. NO.	ITEM	MODEL	GR-SXM330U	GR-SXM535U/UC	GR-SXM530U	GR-SXM536UC	GR-AXM230U	GR-AXM231U/226UC
△ 500	MONITOR ASSY		LYH20217-015A	LYH20217-013A	LYH20217-018A	LYH20217-019A	LYH20217-006A	←
△ 501	M. COVER ASSY		LY20679-009A	LY20679-007A	LY20679-010A	LY20679-008A	LY20679-004A	←
501B	WINDOW		LY32022-001A	←	←	←	LY32022-003A	←
502	M.CASE(2.5/3)ASSY		LY32036-001A	LY32035-001A	LY32036-001A	←	←	←
504	HINGE COVER(U)		LY31939-004A	LY31939-001A	LY31939-004A	LY31939-001A	LY31939-003A	←
515	HOLDER(2.5/3PWB)		*LY20672-001A	LY20647-001A	LY20672-001B	←	*LY20672-001A	LY20672-001B
519	BACK LIGHT		QLL0093-001	QLL0094-001	QLL0093-001	←	←	←
520	LCD MODULE		QLD0176-001	QLD0118-001	QLD0176-001	←	←	←
522	STICKER(B)		LY32059-002A	←	←	←	LY32059-001A	←

MAIN BOARD ASSEMBLY <01>

REF. NO.	ITEM	MODEL	GR-SXM330U	GR-SXM535U/UC	GR-SXM530U	GR-SXM536UC	GR-AXM230U	GR-AXM231U	GR-AXM226UC
PW	MAIN BOARD ASSY		YB10310UD-01	YB10310UF-01	YB10310UK-02	YB10310UM-02	YB10310UC-01	YB10310UI-01	YB10310UL-01

CCD BOARD ASSEMBLY <02>

REF. NO.	ITEM	MODEL	GR-SXM330U	GR-SXM535U/UC/536UC	GR-SXM530U	GR-AXM230U	GR-AXM231U/226UC
PW	CCD BOARD ASSY		YB20899B-01	←	YB20899C-01	←	←
R5301	MG RESISTOR		NRSA02J-105X	←	-	-	-
C5303	CAPACITOR		NCB21HK-102X	←	-	-	-

MONITOR BOARD ASSEMBLY <07>

REF. NO.	ITEM	MODEL	GR-SXM330U	GR-SXM535U/UC	GR-SXM530U/536UC	GR-AXM230U	GR-AXM231U/226UC
PW	MONITOR BOARD ASSY		YB20900B-01	YB20900A-01	YB20900B-01	←	←
R7511,R7512	MG RESISTOR		-	NRSA63J-223X	-	-	-
R7513	MG RESISTOR		NRSA63J-103X	-	NRSA63J-103X	←	←
R7514	MG RESISTOR		-	NRSA63J-333X	-	-	-
R7515	MG RESISTOR		NRSA63J-302X	NRSA63J-562X	NRSA63J-302X	←	←
C7510	CAPACITOR		-	NCB31EK-103X	-	-	-

DSC BOARD ASSEMBLY <08>

REF. NO.	ITEM	MODEL	GR-SXM330U	GR-SXM535U/UC	GR-SXM530U/536UC	GR-AXM230U	GR-AXM231U/226UC
PW	DSC BOARD ASSY		-	-	YB20898B	-	-

Note: Mark - is not used. Mark ← is same as left.